

CHAMBER SPRINGS WATER SYSTEM

CHAMBER SPRINGS RD, OLD HWY 68 AND AR HWY 412

PROJECT NO.: T-2024002

FEB 2024

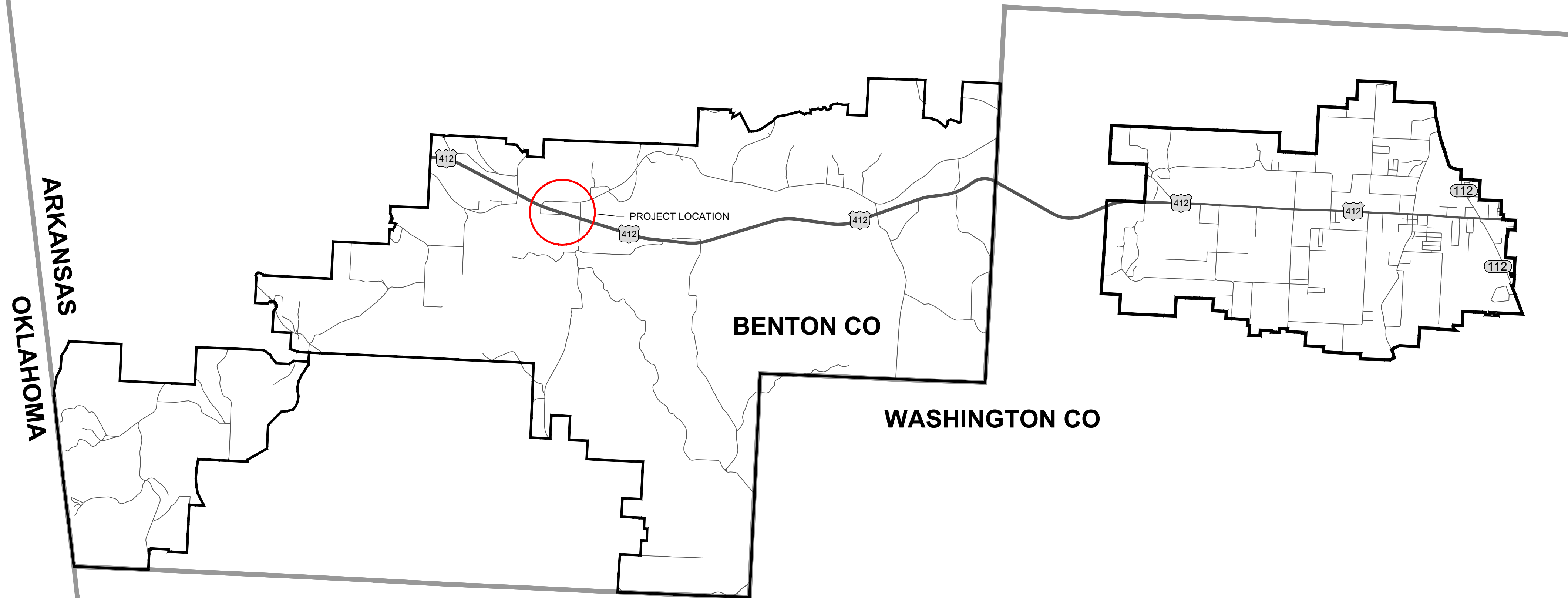

NOTES:

- 1) ELEVATION DATUM IS NAVD 88
- 2) GRADE LINE DENOTES FINISHED GRADE WHERE SHOWN ON PLANS
- 3) ALL PIPE LINES, POWER, TELEPHONE AND TELGRAPH LINES TO BE MOVE OR LOWERED BY OWNER
- 4) ANY EQUIPMENT OR APPURTENANCE THAT INTERFERES WITH THE PROPOSED CONSTRUCTION AND WHICH MAY BE THE PROPERTY OF UTILITY SERVICE ORGANIZATIONS SHALL BE MOVED BY THE OWNER UNLESS OTHERWISE PROVIDED
- 5) THE CONTRACTOR SHALL BE RESPONSIBLE FOR MAINTAINING U.S. MAILBOXES WITHIN THE PROJECT LIMITS IN SUCH A MANNER THAT THE PUBLIC MAY RECEIVE CONTINUED MAIL SERVICE.
- 6) ALL LAND MONUMENTS LOCATED WITHIN THE CONSTRUCTION AREA SHALL BE PROTECTED.
- 7) ALL TREES THAT DO NOT DIRECTLY INTERFERE WITH THE PROPOSED CONSTRUCTION SHALL BE SPARED AS DIRECTED BY THE ENGINEER. CARE AND DISCRETION SHALL BE USED TO ENSURE THAT ALL TREES NOT TO BE REMOVED SHALL BE PROTECTED DURING CONSTRUCTION OPERATIONS
- 8) THE CONTRACTOR SHALL BE RESPONSIBLE FOR PROVIDING A FENCE TO CONTROL LIVESTOCK IN AREAS WHERE PASTURES ARE SEVERED. WIRE FENCE MAY BE CONSTRUCTED INITIALLY, OR IN LIEU THEREOF, THE CONTRACTOR AT THIS OWN EXPENSE, MAY ELECT TO PROVIDE TEMPORARY FENCING SUITABLE TO CONTAIN LIVESTOCK.
- 9) LOCATION AN/OR ELEVATIONS OF EXISTING UTILITIES AS SHOWN ON THESE PLANS ARE APPROXIMATE. THE INFORMATION IS NOT TO BE RELIED ON AS BEING EXACT OR COMPLETE. AT LEAST 48 HOURS PRIOR TO THE BEGINNING OF CONSTRUCTION TO REQUEST EXACT FIELD LOCATION OF UNDERGROUND UTILITIES. ALL UTILITY DISCONNECTIONS AND/OR DISRUPTIONS SHALL BE COORDINATED BY THE CONTRACTOR WITH CITY PERSONNEL, AND/OR THE DESIGNATED UTILITY COMPANIES, AS WELL AS THE AFFECTED RESIDENTS AND PROPERTY OWNERS.
- 10) THE CONTRACTOR IS TO REMOVE AND DISPOSE OF ALL DEBRIS, RUBBISH, AND OTHER MATERIALS RESULTING FROM PREVIOUS AND CURRENT DEMOLITION OPERATIONS. DISPOSAL WILL BE IN ACCORDANCE WITH ALL LOCAL, STATE AND/OR FEDERAL REGULATIONS GOVERNING SUCH OPERATIONS.
- 11) CONTRACTOR SHALL BE HELD SOLELY RESPONSIBLE AND SHALL TAKE ALL PRECAUTIONS NECESSARY TO AVOID PROPERTY DAMAGE TO ADJACENT PROPERTIES DURING THE CONSTRUCTION BASIS AT THE SITE.
- 12) EXISTING GROUND SURFACE PROFILE IS SHOWN FOR INFORMATION PURPOSES ONLY AND IS AN APPROXIMATION OF FIELD TOPOGRAPHY.
- 13) THE CONTRACTOR SHALL CONTROL EROSION ON THE SITE. ALL DISTURBED AREAS SHALL BE SEEDED, FERTILIZED, MULCHED, AND WATERED AS DIRECTED BY THE SPECIFICATIONS AS SOON AS POSSIBLE AFTER CONSTRUCTION ACTIVITY IS COMPLETED. GRASS SHALL BE MAINTAINED AND MOWED AS NEEDED UNTIL THE PROJECT IS COMPLETE AND ACCEPTED. THE SITE SHALL BE GRADED TO MAINTAIN POSITIVE DRAINAGE DURING CONSTRUCTION. WATER SHALL NOT BE ALLOWED TO POND.

CONTACTS

PUBLIC WORKS
 JAMES CLARK
 DIRECTOR
 479.361.2700
 PWDirector@tontitownar.gov

PLANNING
 MARK LATHAM
 CITY PLANNER
 479.361.2700
 Planning@tontitownar.gov

ENGINEERING
 ZAK JOHNSTON
 CITY ENGINEER
 479.435.4270
 Engineer@tontitownar.gov



**SAFETY IS IN YOUR HANDS.
 EVERY DIG. EVERY TIME.**

CHAMBER SPRINGS WATERMAIN EXTENSION PROJECT
 TONTITOWN, AR

REVISION:

DRAWN BY:
 z

DATE:
 2024/02/13

PROJECT NO:
 T-2024002

SHEET:
C-000



VICINITY MAP

1" = 5,000'

CHAMBER SPRINGS WATERMAIN EXTENSION PROJECT
TONTITOWN, AR



PROPOSED WATERMAIN
3,200 LF OF 6" DR 14 C900 PVC
6,850 LF OF 3" SDR 13.5 PVC

PROPOSED WATER STORAGE TANK
ELEVATED STORAGE
25,000 GALLONS
OVERFLOW: 1310'

BWRPWA TRANSMISSION MAIN(S)
18" WATERMAIN
24" WATERMAIN

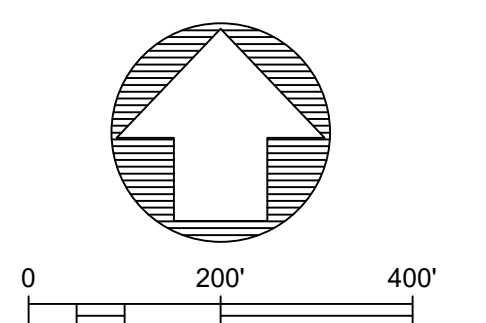

BENTON COUNTY RURAL WATERMAIN EXTENSION

LEGEND

| | |
|--|-----------------------------------|
| | PROPERTY BOUNDARY |
| | EXISTING CONTOUR |
| | EXISTING BWRPWA TRANSMISSION MAIN |
| | PROPOSED WATERMAIN |
| | ROAD ENCASMENT |

| | |
|--------------|-----|
| REVISION: | |
| DRAWN BY: | |
| DATE: | |
| PROJECT NO.: | |
| SHEET: | C01 |